



**nu•cle•us**—the positively charged core of an atom made up of protons and neutrons containing most of the mass of an atom.

patent number: US D463,600S

<b>fixture composition:</b> brass injection die-cast		<b>finish:</b>
<b>energy consumption:</b> 12 volt/20 watt		earth
<b>qty:</b>	<b>contents of box:</b>	 directional
1	atom nucleus® 0111 brass fixture	
1	atom particle® 0712 composite stake	
1	atom 1/2" npt short (installed)	
1	atom mr-16 BAB 20 watt 36° lamp (installed)	
1	5 mm hex allen wrench	
1	1.5 mm hex allen wrench	

0111.PIS revision 10.04

877.922.2866 | atomlighting.com

lamp compatibility

This fixture is recommended for 12 volt lamp operation only. The following mr-16 lamps have tested as suitable for operation with this fixture:

Lamp wattage – ANSI codes: • 20 watt – EZK | ESX | BAB • 35 watt – FRB | FMT | FMW • 50 watt – EXT | EXN | FNV

Contact atom lighting’s corporate office for compatibility verification of any lamp other than listed above. For identification of lamp life, beam spread and other various features reference an ANSI (American National Standards Institute) corresponding lamp publication or atom lighting’s lamp specification guide.

**WARNING!** This fixture is rated for a maximum of 50 watts and 4.167 amps at 12 volts. To reduce personal injury or property damage risk, never exceed this specified wattage or amperage.

fixture maintenance

Each fixture must be inspected annually for damage and wear. Repair any damaged component of the fixture prior to the next operation. Remove mineral deposits from the lens surface using an acetic acid or vinegar-like substance. When replacing the lamp always ensure that an identical lamp is used. Never directly touch the lamp. Oils from bare hands can cause premature lamp life. Examine the ceramic lamp socket for deterioration. If socket replacement is necessary please contact your local distributor for replacement parts. In the event of moisture penetration, dry the inside of the fixture prior to replacing lens cap, cover or shroud. Always lubricate o-ring gaskets, machined threads, hex bolts, and set screws with a silicon grease product to facilitate reliable fixture function and longevity of components.

product warranty

Fixture is guaranteed to be free of defects in material and workmanship for one year from the date of purchase. Each fixture is thoroughly inspected by atom lighting technicians prior to packaging to ensure our product is of the highest quality. This product type undergoes routine durability and safeties testing to ensure compliance of UL 1838 standards are maintained. If a warrantable defect occurs, please return the product to the place of purchase. **DO NOT** operate any fixture with a missing or damaged component. Upon verification by the distributor a repair will be made to the product or a replacement product supplied at no additional costs. All claims after one year must be directed to our corporate office by calling 1-877-922-atom (2866). For additional warranty inquires please contact your local distributor or an atom lighting sales representative.

safety precautions

**WARNING!** Fixture and lamp become extremely hot shortly after power activation. To reduce the risk of personal injury, never touch a hot lens, shroud, cover or lamp housing while fixture is operational. Prevent skin from coming in direct contact with any portion of a hot fixture and avoid prolonged heat exposure radiating from an illuminated lamp. Never look directly at the filament of an operational lamp to prevent eye injury. Always allow each fixture ample time for cooling prior to handling. If a serious burn occurs to the skin or eyes consult a physician immediately. **CAUTION:** Disconnect all power supplies before servicing. Product is intended for outdoor use only. Keep fixture away from excess landscape debris, maintenance clippings and all other flammable materials. Fixture not to be installed within 10 feet (1.52m) of a pool, spa or fountain. Always adhere to the lamp wattage and amperage specifications for proper fixture operation.

© 2004 atom lighting incorporated

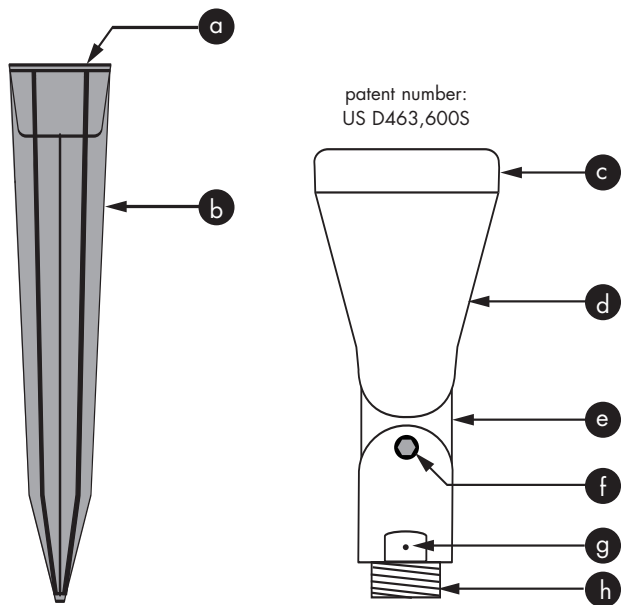

### save these instructions

parts identification	
<b>a</b>	brass 1/2" female npt insert
<b>b</b>	atom particle® 0712 composite stake
<b>c</b>	brass lens cap (patent pending)
<b>d</b>	brass lamp housing
<b>e</b>	brass adjustable knuckle
<b>f</b>	stainless steel hex bolt (5 mm)
<b>g</b>	stainless steel hex set screw (1.5 mm)
<b>h</b>	brass 1/2" npt short

### fixture installation

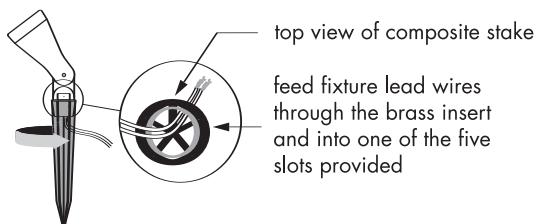

Locate the top of the composite stake and the 1/2" brass insert fitting. Feed fixture lead wires through the brass insert and into one of the five slots provided. Pull the wires through the bottom of the brass insert until the fixture seats against the top of the stake. Fasten the fixture to the stake by threading the 1/2" npt short into the 1/2" npt insert. While holding the fixture stationary rotate the stake clockwise until snug. Do not overtighten. Allow the wire leads to rotate freely while fastening the fixture.

**WARNING: DO NOT feed wires through separate slots. This will cause wiring to twist within the fixture and may result in a fire hazard or short circuit. Personal injury or property damage may result.**

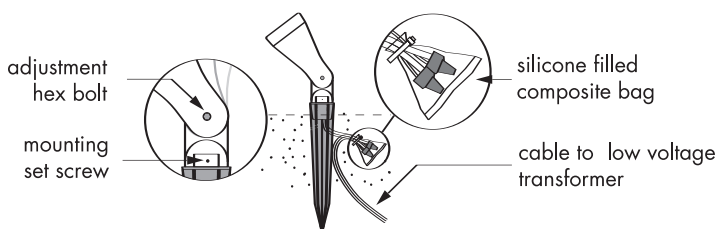

With the fixture now attached to the stake, fasten the lead wires to a UL approved low voltage cable using appropriate sized wire nuts. Cable must be rated for use with 12 volt systems. After a positive connection and voltage has been verified, insert wire nuts into a silicone filled composite bag. Seal the bag and allow silicone to harden to ensure protection from the elements and create a corrosion resistant connection.

As illustrated install the stake into the ground and bury the silicone wire connection a minimum depth of eight inches. Coil ample cable nearby for future adjustments to fixture position. Loosen the adjustable knuckle's hex bolt and rotate the angle of the fixture for desired illumination. As necessary tighten the mounting set screw to ensure that a permanent connection is made between the fixture and stake.

© 2004 atom lighting incorporated

### mounting options

